

SECTION 14. SIGNS

- 14.1 PURPOSE
 - 14.2 SIGN PERMITS
 - 14.3 SIGN PLACEMENT
 - 14.4 SIGN DIMENSION COMPUTATIONS
 - 14.5 GENERAL DESIGN STANDARDS FOR PERMANENT SIGNS
 - 14.6 PERMANENT SIGNS
 - 14.7 EXEMPT PERMANENT SIGNS
 - 14.8 TEMPORARY SIGNS
 - 14.9 PROHIBITED SIGNS
 - 14.10 MASTER SIGN PLAN REQUIRED
 - 14.11 SIGN STANDARDS FOR SPECIAL PURPOSE DISTRICTS
 - 14.12 NONCONFORMING SIGNS
-

14.1 PURPOSE

The purpose of this Section is to establish a framework for a comprehensive system of sign controls governing the display, design, construction, installation and maintenance of signs that will:

- A. Balance the right of business owners to convey their messages, and the right of the public to be protected against the unrestricted proliferation of signs.
- B. Protect the public health, safety, convenience, comfort and general welfare.
- C. Reduce traffic hazards.
- D. Enhance the attractiveness of the City.
- E. Protect property values.
- F. Preserve the right of free speech exercised through the use of signs containing noncommercial messages.

14.2 SIGN PERMITS

Except as otherwise provided in Sections 14.7 and 14.8, it shall be unlawful for any person to erect, relocate, or structurally alter any sign or other advertising structure on any property, public or private, without first obtaining a sign permit from the City. The Zoning Administrator may revoke any sign permit where there has been a violation of the provisions of this Ordinance or a misrepresentation of fact on the sign permit application. As required in Section 4.10 (Sign Permit), the following permanent signs are subject to Appearance Commission approval before a sign permit can be issued: awning and canopy signs, ground (monument or pole) signs, marquees, projecting signs and wall signs. No sign is exempt from permit requirements unless specifically set forth in Sections 14.7 and 14.8 and then only to the extent that such sign complies with the limitations as set forth in those sections. If it is of a type that is set forth as exempt, but nonetheless violates the limitations in any manner, it shall be deemed an illegal and prohibited sign. (Ordinance 2008-65, 9/2/2008)

14.3 SIGN PLACEMENT

A. Signs on Public Property (Ordinance 2008-65, 9/2/2008)

No signs shall be placed or erected on any public property, except as follows:

1. Those placed by federal, state and/or local governments.
2. Those whose placement has been authorized by the Zoning Administrator pursuant to this Section 14.
3. On any day of a federal, state or local election, as called by the Clerk of Cook County, election signs may be placed in the City parkway starting at 4:00 a.m. on the day of the election. These signs may not be placed within 100 feet of the door of the polling place. These signs shall be removed at any time the City Manager, or his or her designee, believes that the signs constitute a hazard to the public. These signs must be removed within twenty-four hours of the close of the polls.

Any sign placed on public property without authorization may be removed by the City without notice.

B. Signs on Private Property

No signs shall be placed on any private property without prior consent of the property.

C. View Obstruction

All signs shall comply with the view obstruction provisions of Section 11.2.G of this Zoning Ordinance (View Obstruction).

14.4 SIGN DIMENSION COMPUTATIONS

The following principles shall control the computation of sign dimensions.

A. Computation of Area of Individual Signs

The area of a sign face shall be computed by means of the smallest square, circle, rectangle or triangle that will encompass the extreme limits of the writing, representation, emblem, or other display, together with any material or color forming an integral part of the background or the display, or used to differentiate the sign from the backdrop or structure against which it is placed, but shall not include any supporting framework or bracing, unless such framework or bracing is made part of the message or face of the sign. See illustrations in Appendix E (Sign Area Illustrations).

B. Computation of Area of Multiple-Faced Signs

1. Unless stated otherwise in this Section 14, the sign area for a sign with more than one (1) face shall be computed by adding together the area of all sign faces visible from any one point.
2. When two (2) identical sign faces are placed back to back in parallel, so that both faces cannot be viewed from any point at the same time, are part of the same sign structure, and are no more than twenty-four (24) inches apart, the sign area shall be computed by the measurement of one (1) of the faces.

C. Measurement of Sign Height

Sign height shall be measured from grade, as defined in this Ordinance, at the sign base to the highest point of the sign.

14.5 GENERAL DESIGN STANDARDS FOR PERMANENT SIGNS

A. Construction and Design Standards

All signs constructed, erected, modified or altered shall comply with the provisions of this Section and the requirements of structures in the Municipal Code.

B. Wind Pressure and Direct Load Requirements

All signs shall be designed and constructed to withstand a wind pressure and receive dead loads as required in the Municipal Code.

C. Illumination

1. Goose-neck reflectors and lights shall be permitted on ground signs and wall signs; provided, however, the reflectors shall concentrate the illumination upon the area of the sign so as to prevent glare upon the street or adjacent property.
2. All sign illumination shall be designed, located, shielded and directed so as to prevent the casting of glare or direct light upon adjacent publicly dedicated roadways and surrounding properties and prevent distraction of operators of vehicles or pedestrians in the public right-of-way.
3. Time-and-temperature signs shall be exempt from the provisions of this Paragraph C.

D. Landscape Requirements

Ground signs shall be landscaped at the base of the sign in accordance with the following:

1. The landscaping shall extend a minimum of one (1) foot from the sign base on all sides.
2. Monument signs shall be landscaped with small shrubs a minimum of two (2) feet in height at planting. (See Figure 20: Ground Sign Landscaping) The remainder of the landscaped area shall be planted with perennials, turf or other live groundcover. If the monument sign is designed with a decorative base, the Planning and Zoning Commission may waive landscaping requirements.
3. Pole signs shall be landscaped with shrubs, a minimum of four (4) feet at planting. (See Figure 20) The remainder of the landscaped area shall be planted with perennials, turf or other groundcover.

FIGURE 20: GROUND SIGN LANDSCAPING

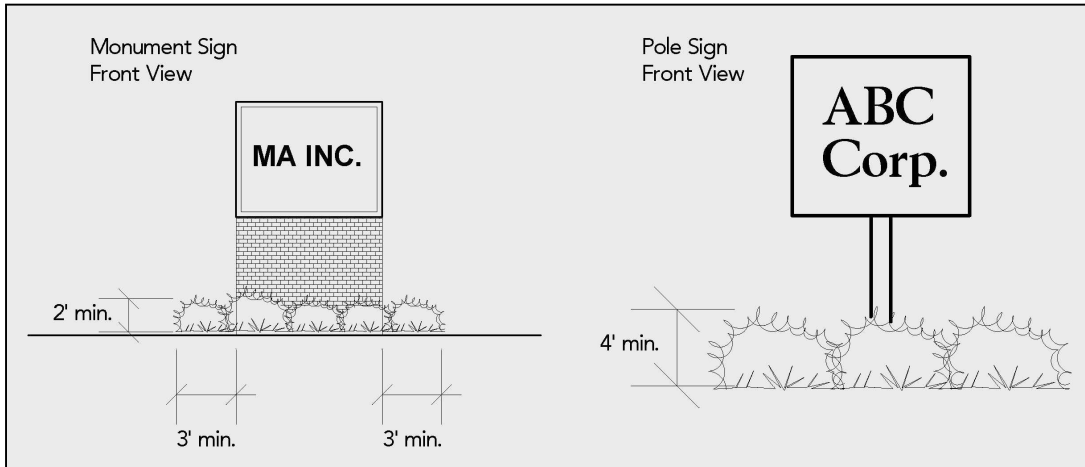

E. Glass

Any glass forming a part of any sign shall be wired glass or safety glass.

F. Lettering

All letters, figures, characters or representations in cut-out or irregular form, maintained in conjunction with, attached to, or superimposed upon any sign shall be safely and securely built or attached to the sign structure.

G. Limitation on Items of Information

1. So as not to create traffic hazards for passing motorists and to minimize the cluttered appearance of signs, all signs shall limit the number of items of information on any single sign face to no more than three (3) items. Items of information may include: the name of the business, type of use, product or service (if not part of the business name), street address, phone number, website address, business logo, business slogan, or other business information.
2. Ground signs for developments with multiple tenants that are used to advertise which tenants are located within the development shall be limited to one (1) item of information per tenant within the development, in addition to the address of the development.
3. For commercial development with multiple tenants, where more than one (1) wall, awning or canopy sign is proposed, a master sign plan is required in accordance with Section 14.10 (Master Sign Plan Required).

H. Data to be Posted

Every sign or other advertising structure shall have painted in a conspicuous place, in letters not less than one (1) inch in height, the date of erection, the permit number and the voltage of any electrical apparatus used in connection therewith. Such information shall not count toward the limitation on the items of information described in Paragraph G above.

I. Sign and Premises Maintenance

1. All temporary and permanent signs, and the premises surrounding such signs, shall be maintained in a clean and sanitary condition, and free and clear of all noxious

substances, rubbish and weeds. All ground signs shall be landscaped as required in Paragraph D above. Such landscaping shall be maintained in good condition.

2. If any temporary or permanent sign or other advertising structure has been constructed or erected or is being maintained in violation of the provisions of this Section 14, the Zoning Administrator shall give written notice of such violation to the permittee. If permittee fails to remove or alter the structure so as to comply with the applicable standards, within twenty (20) days after such notice, such sign or other advertising structure, as defined in this Section, may be removed by order of the City Manager at the expense of the permittee or the owner of the property upon which it is located. The City Manager may cause any other sign or other advertising structure which is an immediate peril to the health, safety or welfare of persons or property to be removed summarily and without notice.

14.6 PERMANENT SIGNS

The construction, erection, modification or alteration of all signs in residential and commercial districts shall comply with the provisions of this Ordinance and the requirements of the Municipal Code. Section 14.11 "Additional Sign Standards for Special Purpose Districts" contains provisions for the Special Purpose Districts. Figures 29A-C: Permanent Sign Regulations for Business Districts, found at the end of this Section, illustrates the general permanent sign regulations for each of the four business districts.

A. Awnings and Canopies (Ordinance 2009-50, 7/6/2009)

Awnings and canopies that are considered an architectural feature of a structure and are not used for identifying the premises or the goods and/or services sold are not considered a sign. Awnings and canopies used as signs are subject to the following regulations:

1. No portion of an awning or canopy sign shall be less than eight (8) feet above the level of the public sidewalk or thoroughfare over which it is erected. (See Figure 21: Awnings and Canopies)
2. No awning or canopy sign shall be permitted to extend beyond any point that is less than four (4) feet from the curb line. (See Figure 21)

FIGURE 21: AWNINGS AND CANOPIES

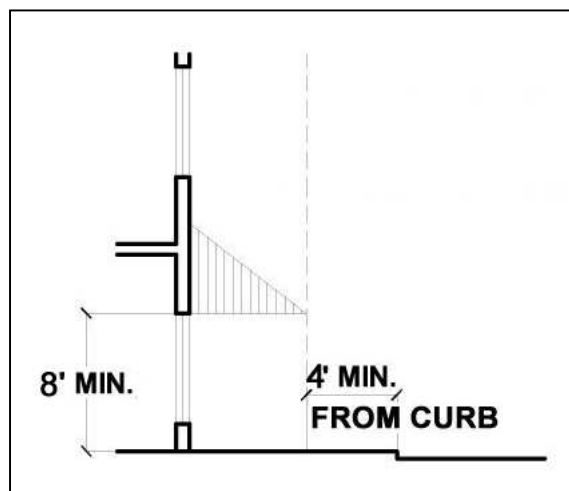

3. Awning and canopy signs shall be constructed out of canvas or canvas-like material, unless other material is approved by the Zoning Administrator. Back-lit and metal awnings and canopies are prohibited.
4. Awning and canopy signs shall be securely attached to and supported by a building. All frames and supports shall be made of metal or other similar rigid material.
5. Only the name of the business, the service offered by that business, street address number (no street name), and/or logo may be printed on the awning sign and shall be restricted to the valance only, except as permitted in Paragraph 6 below. Such valance shall be no more than eight (8) inches in height and any lettering printed on such valance shall be no more than six (6) inches in height.
6. In lieu of a wall sign, the name of the business or logo may be printed on the portion of the awning or canopy above the valance. Printing above the valance shall be limited to one (1) awning or canopy only, except in the case of a corner lot where one (1) awning or canopy with printing above the valance shall be permitted on each street frontage, in lieu of a wall sign. Such name or logo printed above the valance shall be limited as follows (see [Figure 22: Printing on Awnings or Canopies \(Above Valance\)](#)):
 - a. Lettering shall be limited to twenty-five percent (25%) of the height of the awning or canopy, as measured from the point of attachment to the building to the bottom of the fully extended awning or canopy excluding the valance. Lettering shall also be limited to fifty percent (50%) of the width of the awning. (See [Figure 22](#))
 - b. A logo shall be limited to fifty percent (50%) of the height of the awning or canopy, as measured from the point of attachment to the building to the bottom of the fully extended awning or canopy excluding the valance. (See [Figure 22](#))

FIGURE 22: PRINTING ON AWNINGS AND CANOPIES (ABOVE VALANCE)

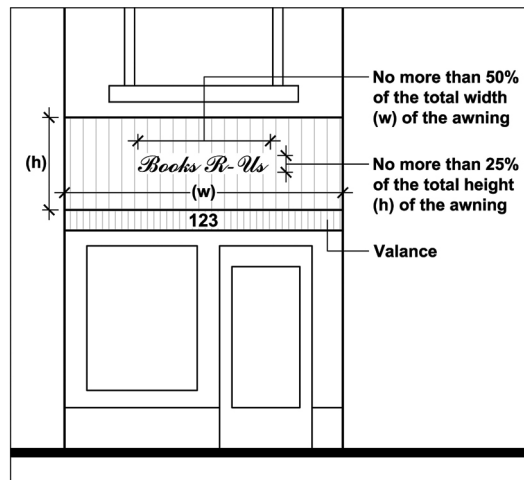

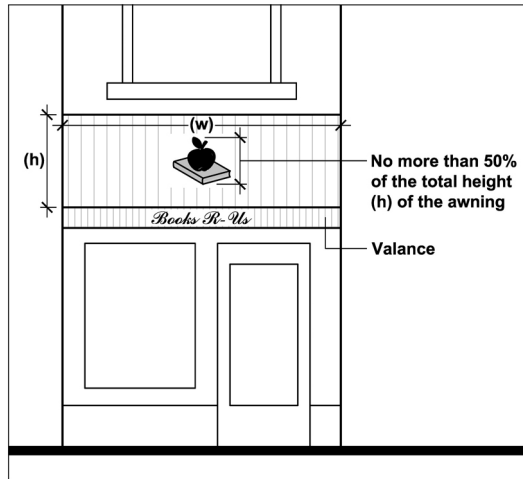

7. All awning and canopy signs shall comply with the following design standards:
 - a. Awnings and canopies shall be compatible in material and construction to the style and character of the building. The color of the awning or canopy shall be compatible with the overall color scheme of the façade.
 - b. When feasible, awnings and canopies shall be generally aligned with others nearby in order to maintain a sense of visual continuity.
 - c. Awnings and canopies shall be tailored to serve the opening into the building and positioned so that distinctive architectural features remain visible.

B. Ground Monument Sign

Ground monument signs are permitted in all commercial districts, except the Uptown Core Sub-District and the Uptown Commercial Sub-District in the B-4 District, and for non-residential uses within residential districts, subject to the following:

1. In residential districts and the B-1 District and the Community Service Sub-District, Transitional Commercial Sub-District and Public/Institutional Sub-District of the B-4 District, ground monument signs shall be limited to six (6) feet in height and thirty-two (32) square feet in sign area. In all other districts, such signs shall be limited to eight (8) feet in height and fifty (50) square feet in sign area. (See Figure 23: Ground Monument Sign Size) However, multi-family dwellings in any district shall be permitted one (1) ground monument sign, subject to the requirements of Paragraph 5 below.

FIGURE 23: GROUND MONUMENT SIGN SIZE

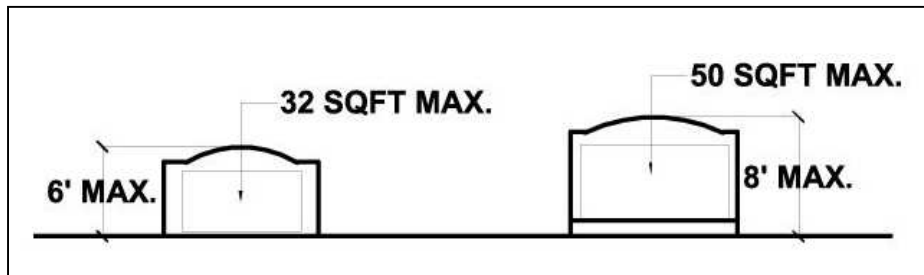

2. There shall be only one (1) ground sign per lot, whether monument or pole ground sign, except that on a corner lot two (2) monument ground signs, one facing each street, shall be permitted. All monument signs shall be set back from the property line a minimum of five (5) feet, except for ground monument signs located in the B-3 Zoning District, which may encroach up to the property line; however, no part of any monument sign shall be located on the public right-of-way. (See Figure 24: Ground Sign Setback) Directional signs, subject to the requirements of Section 14.7.C (Directional Signs (Permanent)), are permitted in addition to other monument signs on that lot. (Ordinance 2009-50, 7/6/2009)

FIGURE 24: GROUND SIGN SETBACK

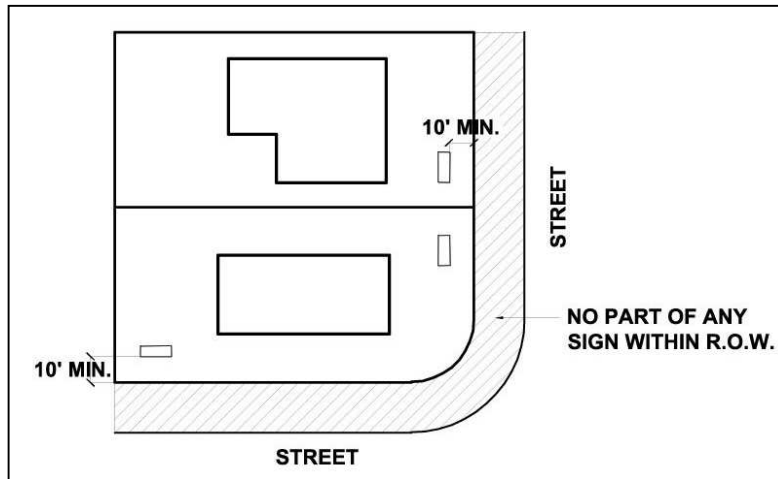

3. The sign base of any ground monument sign shall be a minimum of seventy-five percent (75%) of the width of the sign face that is to be situated upon the base. (See Figure 25: Monument Sign Base)

FIGURE 25: MONUMENT SIGN BASE

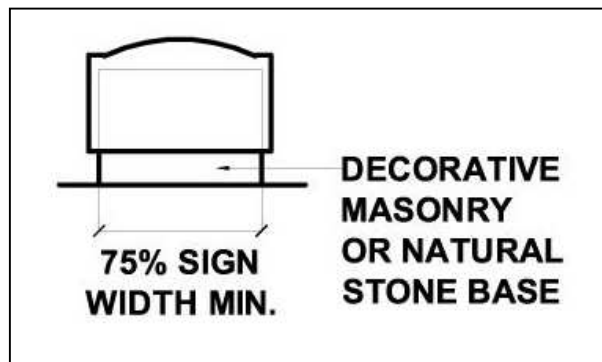

4. Monument signs shall be mounted on either a decorative masonry or natural stone base. Where a monument sign is to be constructed for a non-residential use located within a brick or decorative masonry building, the sign base shall be constructed of a decorative masonry material.
5. One (1) multi-family dwelling ground monument sign may be displayed for a multi-family dwelling in any district. Only the name and address of the building, and the name of the manager may be contained on the sign. No sign shall be higher than six (6) feet above the established grade, nor shall such sign project beyond the property line. The size of such sign shall not exceed:
 - a. Nine (9) square feet for multi-family dwellings containing ten (10) dwelling units or less.
 - b. Twenty-four (24) square feet for multi-family dwellings containing more than ten (10) dwelling units.

C. Ground Pole Sign

Ground freestanding poles signs shall be permitted only in the B-2 and B-3 Districts, subject to the following:

1. The maximum height of pole signs shall be limited to twenty (20) feet in height. Freestanding pole signs are limited to thirty-two (32) square feet in sign area in the B-2 District and fifty (50) square feet in sign area in the B-3 District. (See [Figure 26: Ground Pole Sign Size](#))

FIGURE 26: GROUND POLE SIGN SIZE

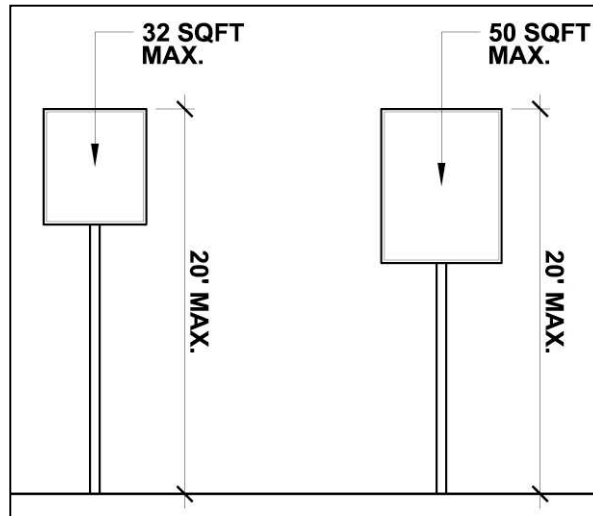

2. There shall be only one (1) ground sign per lot, whether pole or monument ground sign, except that on a corner lot one (1) additional pole ground sign shall be permitted for each street frontage of two-hundred (200) feet or more. All pole signs shall be set back from the property line a minimum of ten (10) feet; however, no part of any pole sign shall be located on or over the public right-of-way. (See [Figure 24](#) above) Directional signs, subject to the requirements of Section 14.7.C (Directional Signs (Permanent)), are permitted in addition to other pole signs on that lot.
3. The primary support of a pole sign shall be erected in such a manner that at least forty-two (42) inches of the length of the support is underground. This requirement may be modified based upon the size of the sign and the height of the sign, at the discretion of the Zoning Administrator. The Zoning Administrator may require, in cases of signs over ten (10) feet in height, proper documentation from a structural engineer or manufacturer that indicates proper installation instructions for the sign, as well as the sign's ability to withstand wind pressures.

D. Marquee

Marquee signs are permitted in the U-Core Sub-District of the B-4 District subject to the following:

1. No marquee shall be extend beyond the curb line.
2. Marquees shall be not less than the width of the building entrance and extend not more than five (5) feet beyond each side of the entrance.

3. Marquees shall only be permitted on zoning lots of thirty-five thousand (35,000) square feet or more.
4. No temporary sign shall be attached to, or hung from, a marquee except a sign painted or illuminated directly upon the vertical hanging fascia of the marquee, or where design for changeable copy. No sign shall extend vertically or horizontally beyond the limits of the marquee, except that individual, free-standing letters may project to a height not exceeding two (2) feet above such marquee
5. All marquees, including the anchor bolts, supports, rods, and braces, shall be designed by a structural engineer and subject to the approval of the Zoning Administrator. Marquees shall be supported solely by the building to which they are attached, and no columns or posts shall be permitted for support or any other purpose. No marquee shall be erected on any building of wood frame construction.
6. The roofs of all marquees shall be used for no other purpose than to form and constitute a roof. No portion of a marquee shall be less than eight (8) feet above the level of the sidewalk or other public thoroughfare over which it projects.

E. Projecting Sign

Projecting signs shall be permitted only in the B-1 and B-4 Districts, subject to the following:

1. Projecting signs shall not exceed six (6) square feet in sign area. There may be only one (1) projecting sign per zoning lot. (See [Figure 27: Projecting Sign](#))
2. Projecting signs shall not project more than four (4) feet from the face of the building to which they are attached, measuring from the point on the sign nearest the wall. (See [Figure 27](#))
3. Projecting signs shall be permitted to encroach two (2) feet into the public right-of-way. The bottom of any projecting sign shall be at least ten (10) feet above the sidewalk or thoroughfare. Projecting signs should be located on that portion of the building immediately above the first floor windows and below the second floor window sills in the case of a two-story building. (See [Figure 27](#))

FIGURE 27: PROJECTING SIGN

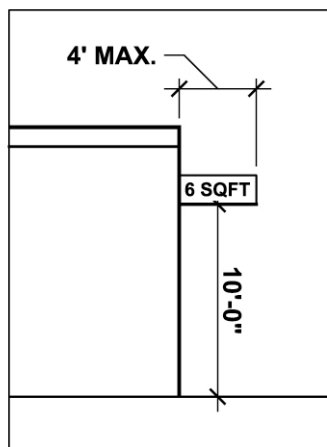

4. No projecting sign affixed to a building, including the sign support structure, shall project above the building height.
5. Projecting signs, including frames, braces, and supports shall be designed by a structural engineer or manufacturer. No projecting sign shall be secured with wire, strips of wood or nails nor shall any projecting sign be hung or secured to any other sign. Any movable part of a projecting sign such as the cover of a service opening shall be securely fastened by chains or hinges. Projecting signs shall neither be attached to, nor supported by, frame buildings nor the wooden framework of a building.
6. No floodlight, spotlight or reflectors of the goose-neck type shall be permitted on projecting signs. No projecting sign with internal illumination of any kind shall be permitted.

F. Wall Sign (Ordinance 2008-65, 9/2/2008)

Wall signs are permitted for any non-residential use in any district subject to the following:

1. No more than one (1) wall sign shall be allowed on any wall facing a public street, except in the case of a multi-tenant building, where no more than one (1) wall sign shall be allowed for each ground floor tenant unit. Wall signs are not allowed on walls that do not face a public street, except where a building has a secondary entrance, such as a rear parking lot, an additional wall sign is permitted but shall be limited to no more than sixteen (16) square feet and shall only indicate the name of the business and the words "entrance," "enter" or similar term.
2. Wall signs should be located on the sign frieze, or the portion of the building immediately above the first floor window and below the second floor window sills in the case of a two-story building. No wall sign shall be permitted to rise above the second story sill line. On one-story buildings, the top of the sign shall be no more than ten (10) feet above the top of the main display window on the first floor. (Ordinance 2011-17, 3/7/2011)
3. Wall signs may also be erected on the lower plane of a mansard style roof or mansard wall facing provided such mansard roof or wall facing is constructed at an angle of not less than seventy degrees (70°) from the horizontal plane.
4. A wall sign may be placed on the wall above a window or door. A wall sign may not cover any portion of an architectural detail, window or door. A transom shall be deemed to be an architectural detail and an integral part of a door, whether operable or not.
5. Wall signs shall be constructed of wood or metal. Any other material shall require approval of the Zoning Administrator.
6. Within the business districts, the maximum size of a wall sign shall be established as follows:
 - a. The primary wall sign for a business must face a public street and shall be limited to one (1) square foot per lineal foot of front lot line.
 - b. For properties facing more than one (1) public street, businesses shall be allowed to have one (1) secondary wall sign for each side of a building facing a public street other than the wall where a primary wall sign is located. A secondary wall sign shall be limited to one-half (0.5) a square foot per lineal foot of front lot line.

- c. For multi-tenant buildings, a wall sign for a ground floor tenant unit shall be limited to one (1) square foot per lineal foot of storefront for that unit.
- 7. Within residential districts, only one (1) wall sign shall be allowed and it must face a public street. The wall sign shall be limited to thirty-two (32) square feet.
- 8. Wall signs shall be safely and securely attached to the building wall. Wall signs shall be affixed flat against the building wall and no part of the sign may project more than twelve (12) inches from the building wall. No wall sign, including sign support structure shall project beyond the ends or top of the wall to which it is attached. (See [Figure 28: Wall Sign](#))

FIGURE 28: WALL SIGN

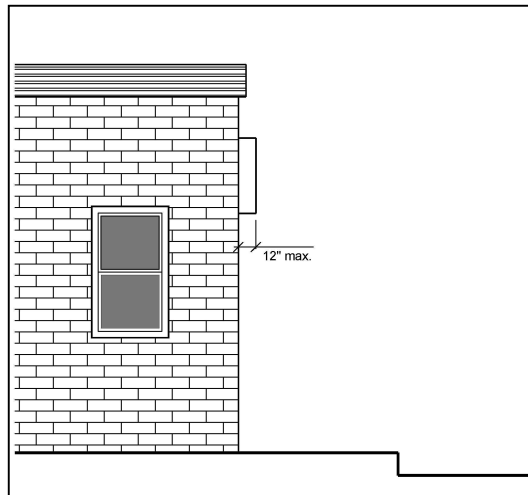

G. Window Signs (Permanent)

Window signs are permitted for any commercial use in any district subject to the following:

- 1. Permanent window signs affixed to or painted on the inside of a window and advertising the business, the service offered by such business and/or logo may occupy no more than twenty-five percent (25%) of the surface of each windowpane area. Permanent window signs are permitted on the upper floors of multi-story commercial buildings.
- 2. The total area of all temporary and permanent window signs shall be no more than fifty percent (50%) of the total window area. Temporary window signs shall be subject to the regulations of Section 14.8.A.8 (Window Signs (Temporary)).
- 3. Neon window lighting shall be considered a permanent window sign and shall be included in the twenty-five percent (25%) limitation set forth in (1) above. However, no more than fifteen percent (15%) of total window area may be occupied by neon window signs. Neon window signs shall be measured by the height and width of the sign.
- 4. Series lighting or neon tubing used to accentuate or trim windows, architectural features, or to outline borders of windows, signs or buildings, is specifically prohibited. Neon window signs are prohibited in the residential or special purpose districts.

H. Signs Placed on Automatic Teller Machines (Ordinance 2008-65, 9/2/2008)

Signs on automatic teller machines (ATMs) are allowed in all commercial uses in any district, subject to the following:

1. With respect to a drive-through facility or other exterior portion of a commercial building, signs on ATMs are allowed on the ATMs only.
2. Signs on ATMs may contain only the word ATM and/or the name of the financial institution, excluding logos.
3. Only one (1) sign is permitted for each ATM. The size of the sign shall be no more than three (3) square-feet and shall be on no more than one (1) side of the ATM.

I. Directional Signs (Permanent) (Ordinance 2009-50, 7/6/2009)

Directional signs shall be exempt from sign permit requirements subject to the following:

1. Directional signs shall be located entirely on the property to which they pertain and shall identify restrooms, public telephone, walkways, parking lot entrances and exits and features of a similar nature, but use logos, shape or color to do so. Directional sign shall not include words identifying or advertising the use.
2. One (1) directional sign is permitted for each driveway access from a public street. One (1) additional directional sign is permitted for each intersection of driveways within a site, to identify traffic routing, entrances and services, such as drive-in lanes.
3. Directional signs shall not project beyond the property line.
4. Directional signs may have a maximum height of six (6) feet and a maximum surface area of three (3) square feet.
5. In addition, one (1) sign per parking area that designates the conditions of use or identity of such parking area shall be permitted. Such a sign shall be limited to a maximum height of seven (7) feet, when freestanding, and a maximum surface area of nine (9) square feet.

14.7 EXEMPT PERMANENT SIGNS

The following permanent signs are exempt from the sign permit requirements of this Ordinance. If the limitations set forth are violated and no sign permit has been issued, the penalty provisions of this Ordinance shall apply. No exempt signs shall encroach upon the public right-of-way. All signs must comply with the view obstruction requirements of Section 11.2.G (View Obstruction).

A. Bulletin Boards

Bulletin boards not over twelve (12) square feet in area for public, charitable or religious institutions, when located on the premises of said institutions.

B. Directory Signs (Permanent)

Multi-tenant commercial buildings are permitted to have one (1) exterior directory sign at the ground floor entrance to indicate the occupants of the business and the location within the building, such as suite or floor. Such signs shall be limited to six (6) square feet in sign area.

C. Flags

Flags of any government or governmental agency, or any patriotic, religious, charitable, civic, educational or fraternal organization. There shall be no more than four (4) such flags per zoning lot. No flagpole in any district shall exceed forty (40) feet in height.

D. House Number and Identification Signs

1. House number signs, which are not internally illuminated.
2. Identification signs, which contain only the name and address of the building or development and are not illuminated, and do not exceed one (1) square foot in area. There shall not be more than one (1) such sign per dwelling or commercial unit. However, commercial units with a rear entrance or a dwelling with a detached garage located on an alley right-of-way are permitted an additional house number or identification sign at that rear entrance or on that detached garage.

E. Memorial Plaques

Memorial or commemorative plaques or tablets denoting a building name and/or date of erection, or a location of historic significance, and not exceeding four (4) square feet in area.

F. Miscellaneous Information Signs

The following types of miscellaneous information signs:

1. Information appearing on gasoline pumps, and service station rate signs, including the names of grades of fuel and prices and conditions relating to prices such as full or self-service.
2. Information appearing on newspaper vending boxes.
3. Information appearing on or adjacent to entry doors such as PUSH, PULL, OPEN and/or CLOSED.
4. Information appearing on display windows or doors denoting hours of operation, credit cards accepted and similar information.
5. Operating instructions on vending machines.

G. Municipal Signs

Traffic or other municipal signs, legal notices, railroad crossing signs, signs regulating vehicular or pedestrian traffic, or designating or giving direction to streets, schools, historic sites or public buildings, and such temporary emergency or non-advertising signs. Such signs are subject to approval by the City Council.

H. Occupational Signs

Occupational signs denoting only the name and profession of an occupant in a commercial building, public building or residence, mounted on the wall (i.e., wall signs), and not exceeding one (1) square foot in area.

I. Warning Signs

“No Trespassing” or “No Dumping” signs, not exceeding one and one-half (1½) square feet per sign. There may not be more than four (4) such signs per lot; except that special permission may be obtained from the City for additional signs under proven special circumstances.

14.7.1 ALTERATION AND MAINTENANCE OPERATIONS

The following activities shall be exempt from sign permit requirements:

1. Changing of the advertising copy or message on an existing changeable copy sign or similar approved sign, whether illuminated or non-illuminated.
2. Painting, repainting, cleaning, changing permitted items of information, or other normal maintenance and repair of a sign, not involving structural changes or changes in the electrical components of the sign.

14.8 TEMPORARY SIGNS

Temporary signs are permitted in accordance with the provisions of this Section, except that where other sections of this Ordinance regulate such signs, the more restrictive regulation shall apply.

A. Temporary Signs Exempt from Sign Permit Requirements

Subject to compliance with all requirements of this Section 14 and this Zoning Ordinance, the following types of temporary signs are exempt from sign permit requirements:

1. Construction and Home Improvement Services Signs

- a. On-site construction signs identifying the architect, engineer, developer and/or contractor of a construction site. Such signs shall not exceed sixteen (16) square feet in area and six (6) feet in height. Such signs shall not be erected prior to issuance of a building permit and shall be removed no later than seven (7) days after application for a certificate of occupancy or completion of the project, whichever occurs first. Construction signs shall be limited to one (1) sign per street frontage, except in the case of single-family and two-family dwelling construction, where construction signs shall be limited to one (1) sign.
- b. Home improvement services signs, such as landscaping and house painting services. One (1) such sign not to exceed two (2) square feet advertising the name

of the company providing the service and any additional contact information for such service only shall be permitted. Such temporary home improvement services signs may only be displayed for the duration of the project. Once the work is complete, the sign must be removed.

2. Directional Signs for Public Events

Temporary directional signs for a real estate open house or an event held in public building, park or educational institution. Such signs shall be posted no earlier than forty-eight (48) hours prior to, and removed no later than twenty-four (24) hours after, the conclusion of the event to which the sign relates, and shall be limited to four (4) square feet in size.

3. Displays or Decorations for Holidays and Special Occasions

Displays of a primarily decorative nature, and customarily and commonly associated with any national, local or religious holiday shall be exempt from sign permit requirements.

4. "For Sale" and "For Rent" Signs

a. "For Sale" and "For Rent" Property Signs

"For Sale" and "For Rent" signs that do not exceed six (6) square feet in area and which only advertise the sale, rental, lease or management of the premises upon the said signs are located. Ground-mounted signs shall be no more than six (6) feet in height. These signs shall be removed within twenty-four (24) hours of sale or lease. "For Sale" and "For Rent" signs shall be restricted to one (1) sign for interior lots and two (2) signs for corner lots.

b. "For Sale" Vehicle Signs

"For Sale" Vehicle Signs are subject to the following:

- i.** A vehicle "For Sale" sign must be removed within twenty-four (24) hours of the vehicle's sale.
- ii.** A vehicle that displays a "For Sale" or similar sign may be parked only as follows: in a lot where the sale of new or used vehicles is permitted by this Zoning Ordinance; or
- iii.** An individual privately selling a vehicle may park a vehicle with a "For Sale" sign for display at that individual's home, including in the driveway.
- iv.** A vehicle with a "For Sale" sign may not be parked in the public right-of-way.

5. Garage or Yard Sale Signs

Temporary residential garage or yard sale signs. There may be no more than two (2) such signs per sale and such signs may not exceed four (4) square feet each. One (1) sign shall be permitted per lot frontage on the premises containing the sale, or on another property with that properties owner's or tenant's permission. Such signs shall be removed immediately when the garage or yard sale is over.

6. Not-For-Profit Special Event Signs

Temporary signs in conjunction with special events conducted by charitable or not-for-profit organizations, philanthropic campaigns or house of worship activities. Such signs shall not exceed sixteen (16) square feet in area, and shall not be erected earlier than fifteen (15) days in advance of the event and shall be removed within five (5) days of the conclusion of the event. Such signs may be banner signs.

7. Political Signs or Non-Commercial Messages

Political signs subject to the following:

- a. Signs shall be no more than six (6) square feet in area on each side. No more than twenty (20) square feet total of political or non-commercial signs shall be permitted on any zoning lot.
- b. Signs shall not be posted on any public property except as set forth in 14.3(A)3 of this Section 14. Signs are to be posted on private property only, and only with the permission of the property owner.
(Ordinance 2009-50, 7/6/2009) (Ordinance 2011-01, 1/17/2011)

8. Window Signs (Temporary)

Temporary signs affixed to the inside of a window advertising temporary commercial goods or services sold on the premises. The total of all temporary window signs may occupy no more than twenty-five percent (25%) of the window's area. No such temporary window sign shall be in place longer than thirty (30) days.

9. Certain Banners and Pennants

Banners for charitable or not-for-profit organizations within the City, philanthropic campaigns or house of worship activities are permitted in any district. Such banners are exempt from the lot size limitations of Paragraph B(5)(a) below, but must comply with the requirements of Paragraphs ii and iii of paragraph B(5)(a) below.

10. Certain A-Frame Signs

A-frame signs, also known as "sandwich boards," used to advertise a business, its products or its services may be displayed by a retail establishment in a commercial district between the hours of 9:00 a.m. to 9:00 p.m. Only one such sign, not exceeding twenty-four (24) square feet (12' per side) in size shall be permitted for each establishment. The sign may not be placed on roadways and must be placed in such a manner as to not obstruct pedestrian traffic and may only be placed along the actual frontage of the establishment. The sign may be placed on public property as long as a Certificate of Insurance, in an amount determined by the City, is provided to the City prior to displaying the sign.

B. Temporary Signs Requiring Sign Permit

Temporary signs not specifically set forth as exempt from sign permit requirements in Paragraph A above require a sign permit. In addition, such non-exempt temporary signs must comply with the requirements of this Section 14 and the following specific limitations:

1. Time Limit

Such signs shall not be in place for more than ninety (90) days in any calendar year.

2. Amount

There may be only one (1) sign on each street frontage per lot.

3. Advertising

Any advertisement contained on such a sign shall pertain only to the business, industry or pursuit conducted on or within the premises on which such sign is erected or maintained. Non-commercial or political messages are also permitted. No off-premises advertising signs are permitted.

4. Location and Height

- a. No such sign shall extend into the public right-of-way.
- b. Signs attached to a building shall not extend above the building height or, if attached to a permanent sign, shall not extend above the height of the sign.

5. Attention-Getting Devices Not Specifically Set Forth

Attention-getting devices whose purpose is to draw attention to an event, location, service, person or product, shall be deemed a "sign" and require a sign permit.

a. Banners or Pennants

- i. Banners or pennants are only permitted within commercial districts on lots of eighty thousand (80,000) square feet or more.
- ii. No single banner may exceed twelve (12) square feet of surface area.
- iii. Banners and pennants must remain in good condition during the display period. Throughout the display period, corrective action must be taken immediately should there be any problems with the appearance, condition or maintenance of the banners or pennants and support hardware. If the banner is torn in any manner, it shall be deemed to be in violation of this subparagraph iii.

b. Other Attention-Getting Devices

- i. Any attention-getting device that is not a pennant or banner shall be limited to a maximum of thirty-two (32) square feet in commercial districts, and sixteen (16) square feet in residential districts.
- ii. Other advertising devices may be constructed of cloth, canvas, light fabric, cardboard, or other similar light materials, intended to be of temporary construction as approved by the Zoning Administrator.
- iii. Balloon signs are prohibited. Inflatable advertising displays designed to inflate - or move by use of a fan or blower - shall also be considered a balloon sign.

14.9 PROHIBITED SIGNS

It shall be unlawful to erect, allow or maintain the following signs:

A. Advertising Benches

Advertising benches that advertise a business, product or service located on private or public

property.

B. A-Frame Signs

A-frame signs, also known as “sandwich boards,” used to advertise a business, its products or its services are prohibited, except that such signs may be displayed as set forth in Section 14.8(A)10.

C. Banners and Pennants

Banners and pennants are prohibited, except in accordance with Section 14.8 (Temporary Signs).

D. Flashing Signs

No sign shall have blinking or flashing lights, or other illuminating device that has a changing light intensity, brightness or color, traveling/chasing lights, or rotating beacons. Time-and-temperature signs shall be exempt from the provisions of this Paragraph.

E. Illegally Affixed Signs

Any sign painted, pasted or otherwise affixed to any tree, rock, utility pole, hydrant, bridge, sidewalk, curb or street, bench or trash receptacle is prohibited. Logos and labels located on mechanical equipment, recycling bins, trash containers or dumpsters, which are part of the equipment as manufactured and/or installed, shall not be considered illegally affixed signs.

F. Moving Parts

Signs or other advertising structure moving, revolving or rotating parts or visible mechanical movement of any kind, including wind-activated signs. The Zoning Administrator, in concert with the Chief of Police, may allow such signs upon making a written determination submitted to the City Council that such sign does not constitute a traffic hazard. Clocks with movable hands shall be permitted.

G. Obsolete or Abandoned Signs

Any sign that advertises a business, product, service or activity that is no longer located on the premises where the sign is displayed.

H. Off-Premise Signs (Ordinance 2011-46, 8/22/2011)

Off-premise signs which advertise a business not conducted on the premises or a product not sold on the premises are prohibited, with the following exceptions:

1. In commercially zoned districts¹ within six-hundred sixty (660) feet of Interstate 90 (I-90) and Interstate 294 (I-294) off-premise signs shall be permitted, provided the following standards and criteria are adhered to:
 - a. The sign is adjacent to, intended to be viewed from, and within six-hundred sixty (660) feet of Interstate 90 (I-90) or Interstate 294 (I-294) right-of-way. No off-premise sign is allowed more than six-hundred sixty (660) feet from Interstate 90 right-of-way.

¹ This means off-premise signs are prohibited within residential or special purpose districts regardless of whether or not they are within 660 feet of I-90 or I-294.

- b. No off-premise sign shall be erected closer than one-thousand (1,000) linear feet to any other off-premise sign.
 - c. The maximum area of a sign face may not exceed one-hundred (100) square feet.
 - d. The maximum height of the sign may not exceed twenty (20) feet above grade.
 - e. Off-premise signs shall not be erected or maintained in such a place or manner as to obscure or otherwise physically interfere with an official traffic control device or a railroad safety signal or sign, or to obstruct or physically interfere with a driver's view or approaching merging or intersecting traffic.
2. Within a school or park district athletic field or stadium, signs promoting a business, service or product that is the sponsor of a school or park district program are permitted. However, such signs must strictly adhere to the following standards and criteria:
- a. The business, service or product being promoted must be approved, as a program sponsor, by the governing body of the school or park district.
 - b. The type of signs shall be limited as follows:
 - i. temporary free standing A-frame signs of not more than 12 square feet per side; and
 - ii. a sponsorship sign on a single scoreboard, the primary purpose of which scoreboard is informing attendees of the time, score or other information pertinent to the event ("Scoreboard Sign").
 - c. All such signs shall be within the field, stadium or seating area of the field or stadium, and shall be located so as to be seen by those attending the event and not for the purpose of attracting the attention of those passing by the field or stadium.
 - d. No additional lighting (other than that used for the event) shall be permitted to accent an A-frame sign.
 - e. Scoreboard Signs may be electronic and use lights; however, no individual sponsor's message may contain flashing, blinking or chasing lights.
 - f. The scoreboard upon which the Scoreboard Sign is located must be at least 100 yards from any street from which the sponsor's message may be seen.
 - g. A Scoreboard Sign may only be placed below all other information on the scoreboard.
 - h. Signs permitted pursuant to this paragraph H(2) may be displayed only for actual events that are sanctioned by the school or park district.
 - i. Such signs may be displayed not more than two (2) hours before the event and shall be removed or, in the case of a Scoreboard Sign, turned off no later than two (2) hours after the conclusion of the event.

I. Painted-On Signs

Signs painted directly on an exterior wall, roof, fascia, parapet or chimney of a building or fence. This means off-premise signs are prohibited within residential or special purpose districts regardless of whether or not they are within 660 feet of I-90 or I-294.

J. Roof Signs

Roof signs. However, those signs erected on the lower plane of a mansard style roof or mansard wall facing, provided such mansard roof or wall facing is constructed at an angle of not less than seventy degrees (70°) from the horizontal plane, shall be considered “wall signs.”

K. Signs of an Offensive Nature

Signs which display any matter in which the dominant theme of the material taken as a whole appeals to a prurient interest in sex, or is patently offensive because it affronts contemporary community standards relating to the description or representation of sexual matters, and is utterly without redeeming social value.

L. Signs on Parked Vehicles

Signs placed or painted on a vehicle that is parked in a location such that the primary purpose is to advertise a product or service, or to direct the public to a business or activity located on or off the premises are prohibited. Signs displayed on trucks, buses or other vehicles, which are being operated and stored in the normal course of a business, such as signs indicating the owner or business that are located on delivery trucks, moving vans and rental trucks, are permitted, provided that the primary purpose of such vehicles is not the display of signs and that they are parked or stored in areas appropriate to their use as vehicles. Temporary or permanent signs resting on, or attached to, vehicles or trailers used as a means to circumvent the provisions of this Section are prohibited.

M. Traffic Hazards

Signs which:

1. Obstruct the free and clear vision at any street, intersection, parking lot entrance or exit, or driveway.
2. Interfere with, obstruct the view of, or cause confusion with any traffic sign, signal or device because of its position, shape, color or lighting.
3. Make use of the words STOP, LOOK, DETOUR, DANGER or any other word, phrase, symbol or character that tends to mislead, interfere with or confuse the driver of a motor vehicle.
4. Are illuminated in red, green or amber color; if that sign is in the line of sight between the driver of a motor vehicle and a traffic signal light.

N. Obstruction of Doors, Windows or Fire Escapes

Signs which are erected, located or maintained so as to inhibit ingress to and egress from any door, window or fire escape and signs which are attached to a standpipe or fire escape.

O. Strobe Lights, Spotlights and Floodlights

Strobe lights, spotlights and floodlights used to advertise a business, event service or product are prohibited.

P. Trailer and Portable Signs

Trailer and portable signs.

Q. Unsafe Signs

Signs which constitute a hazard to safety or health by reason of inadequate design, construction, repair or maintenance.

14.10 MASTER SIGN PLAN REQUIRED

The purpose of a Master Sign Plan is to provide for coordinated signs on multi-tenant buildings. The intent is to create a plan whereby current owners or tenants can establish a unified sign program for the building and provide sign guidelines to future tenants.

- A. For commercial development with multiple tenants, where more than one (1) wall sign, awning or canopy is proposed, the applicant shall submit a master sign plan for review and approval by the Planning and Zoning Commission.
- B. A master sign plan shall provide for coordinated design for all building-mounted signs and shall include, at a minimum, criteria and specifications for general appearance, format of message, font size and style, lighting, location and construction materials, and shall not cover or overhang any architectural feature. Where signs are to be located on a wall of a multi-tenant strip commercial development, they shall be located at a generally uniform height on the building wall.

14.11 SIGN STANDARDS FOR SPECIAL PURPOSE DISTRICTS

A. Open Space District

Each use permitted in the Open Space District shall be permitted one (1) identification sign not to exceed fifty (50) square feet in sign area. The maximum height of any ground sign shall be ten (10) feet. The minimum setback from the property line for ground signs shall be ten (10) feet.

B. Hospital District

Signs within the Hospital District shall comply with the sign regulations for the B-3 District (as shown in Figure 29C), except as follows:

1. Directional Signs (Permanent)

- a. Such signs may designate hospital, parking, walkways, emergency room locations, and other hospital-related facilities, as well as entrances or exits, by means of symbols or words.
- b. One (1) directional sign is permitted for each driveway access from a public street. One (1) additional directional sign is permitted for each intersection of driveways within a site, to identify traffic routing, entrances and services, such as drive-in lanes. Additional directional signs may be permitted subject to Zoning Administrator approval.
- c. Directional signs shall be located entirely on the property to which they pertain. Directional signs shall not project beyond the property line.

- d. Directional signs may have a maximum height of seven (7) feet and a maximum surface area of thirty-two (32) square feet. (Ordinance 2009-50, 7/6/2009)
- e. Directional signs may be illuminated.

2. Wall Signs

One (1) wall sign for identification of each building shall be permitted provided the surface area of such sign shall not exceed one-hundred (100) square feet.

C. Educational Boarding District

All signs and sign regulations that are permitted and applicable within the B-2 District shall apply to the Educational Boarding District.

D. Sexually-Oriented Business District

All signs and sign regulations that are permitted and applicable within the B-2 District shall apply to the Sexually-Oriented Business District. However, electronic message signs are prohibited.

E. Parking District

Only directional signs, in accordance with Section 14.7.B (Directory Signs (Permanent)), shall be permitted in the Parking District.

14.12 NONCONFORMING SIGNS

Any sign lawfully existing prior to the enactment of this Section, but which could not be erected in accordance with the provisions of this Section shall be deemed to be a legally nonconforming sign and may continue to be in existence with the following conditions:

- A. The sign must be properly maintained in a safe condition. No nonconforming sign shall have any changes made in the words or symbols used or the message displayed on the sign unless the sign is specifically designed for changeable copy. Any other changes made will be to bring the nonconforming sign into conformance with the provisions of this Section.
- B. No nonconforming sign shall be allowed to remain after the activity, business, or use to which it relates has been discontinued.
- C. If a nonconforming sign is damaged in such a manner that the estimated expense of repairs exceeds fifty percent (50%) of its replacement value, the sign shall not be allowed to remain and must be removed.
- D. Nothing in this Section shall relieve the owner or user of a legal nonconforming sign or structure, or the owner of the property on which it is located, from the provisions of this Section regarding safety, maintenance and repair of signs and structures. However, any repainting, cleaning or other normal maintenance or repair hereof shall not modify the sign, structure or copy in any way which makes it more nonconforming.

FIGURES 29A-C: PERMANENT SIGN REGULATIONS FOR BUSINESS DISTRICTS

FIGURE 29A: B1 AND B4 DISTRICTS

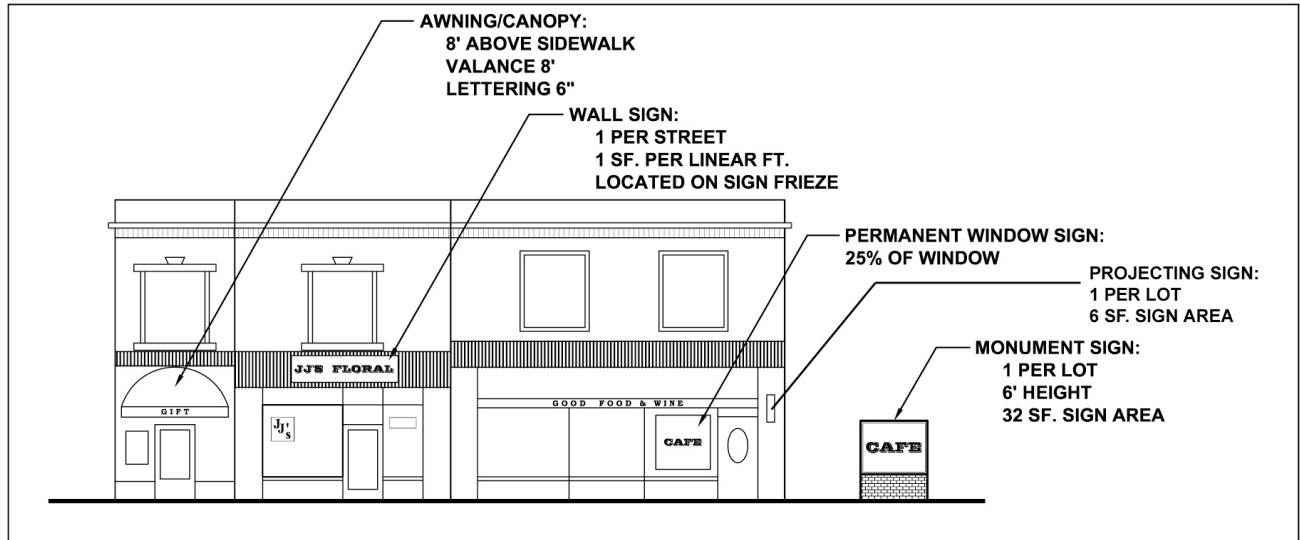
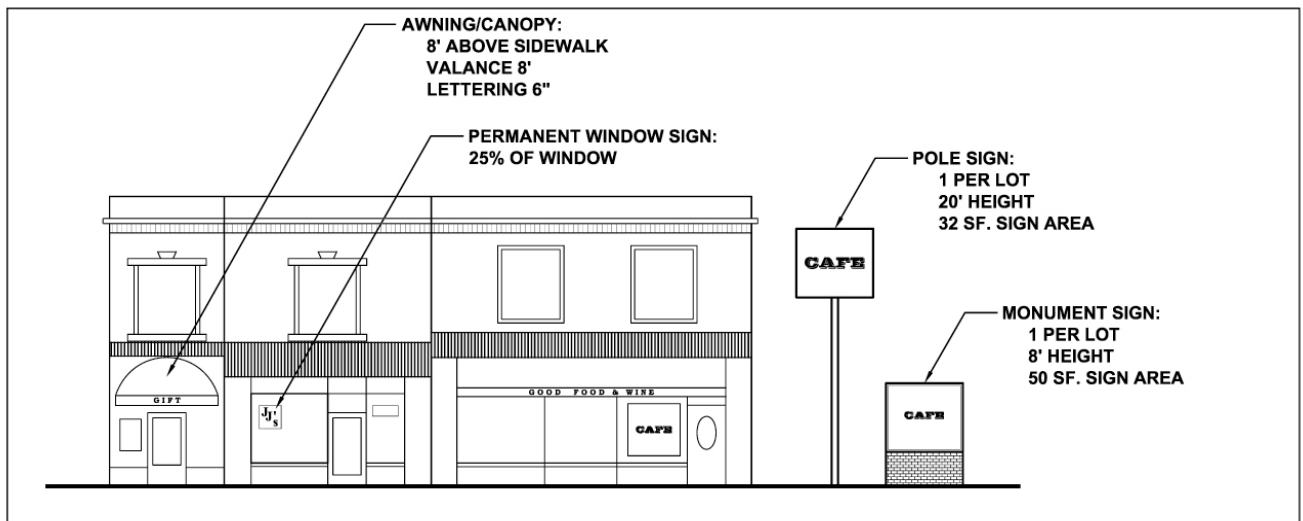
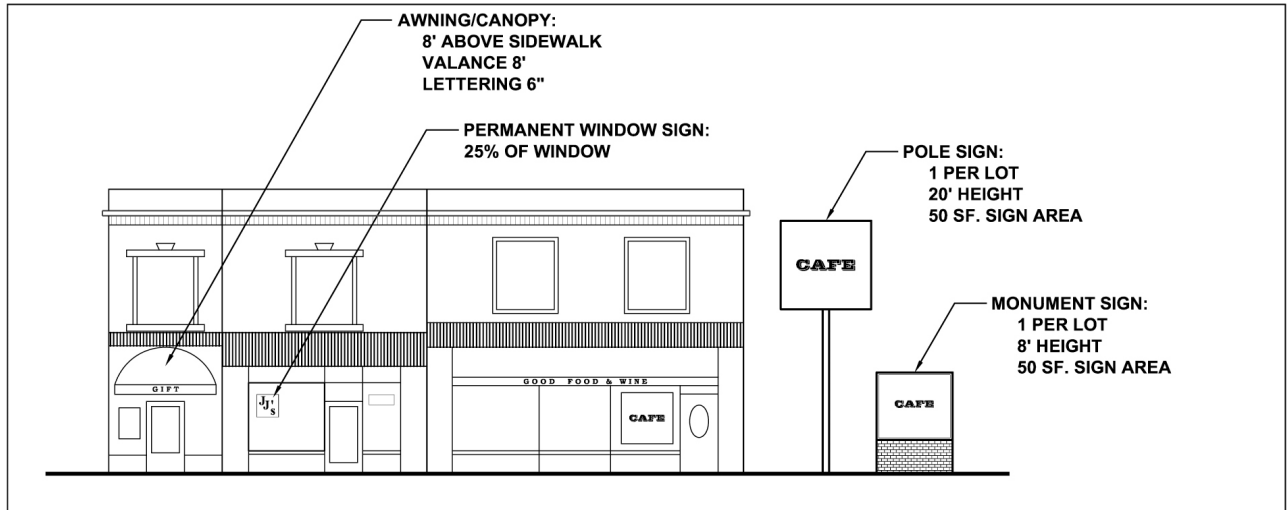

FIGURE 29B: B2 DISTRICT



NOTE: There shall be only one (1) ground sign per lot, whether monument or pole ground sign, except that on a corner lot two (2) monument ground signs, one facing each street, shall be permitted. There shall be only one (1) ground sign per lot, whether pole or monument ground sign, except that on a corner lot one (1) additional pole ground sign shall be permitted for each street frontage of two-hundred (200) feet or more.

FIGURE 29C: B3 DISTRICT



NOTE: There shall be only one (1) ground sign per lot, whether monument or pole ground sign, except that on a corner lot two (2) monument ground signs, one facing each street, shall be permitted. There shall be only one (1) ground sign per lot, whether pole or monument ground sign, except that on a corner lot one (1) additional pole ground sign shall be permitted for each street frontage of two-hundred (200) feet or more.